



# USER MANUAL

ONE-STOP SOLUTION

ONE-STOP SERVICE

## MRCM600 Radar Flow Meter Instruction Manual

### Note

Users of this manual must be aware of the dangers that this instrument and its accessories may pose.

All operators should be familiar with the safety instructions and warnings in this section before operating this instrument. Failure to follow the operating instructions may reduce the performance of the instrument or cause harm to humans.

Cautions and restrictions on use

Note: The design and manufacture of radar flow meter products are safe and reliable. Please use them correctly (in accordance with the text shown) and fully observe the following precautions, which will not cause harm to the instrument and human body.

#### Example:

⚠Instructions: Attention / Warning

Please refer to the precautions during transportation, use and maintenance.

Things to note are as follows:

#### Operating environment and power consumption precautions

⚠WARNING: Do not use the instrument in locations where flammable or explosive gases are or may be present.

⚠Note: Do not expose the instrument to water or place it in water.

⚠Note: Do not place the instrument in extreme temperatures and avoid static electricity.

#### Instrument operation

Note: Regardless of the use, storage or transportation of the instrument, it should be handled with care and not damaged.

Note: The installation and setting of this radar flow meter can only be installed and operated by professional technicians.

Note: Please do not disassemble or modify the radar flow meter, otherwise the warranty will not be given.

Note: If the instrument fails, please be sure to send it to our company for after-sale repair.

Do not disassemble it by yourself!

**RS232 interface, RS485 interface**

Warning: The system equipment or computer equipment connected to the RS232 interface or RS485 must comply with the BS EN60950 / IEC950 standard.

**Instrument parts**

WARNING: This instrument is not equipped with internal spare parts and you must not disassemble the instrument parts without authorization.

**Hazardous Substance Management**

When discarding MRCM600, please observe the hazardous substance management regulations and dispose of as waste electronic / electrical products.

Warning: Do not dispose of used equipment in classified waste or municipal waste.

**Use restrictions**

The design of MRCM600 meets the requirements of regularity and safety.

**Statement**

MRCM600 is designed to meet and adhere to the requirements of low voltage specifications.

## Contents

<b>1 Product Introduction .....</b>	<b>1</b>
1.1 Product Introduction .....	1
1.2 Measurement principle .....	1
1.2.1 Principle of flow velocity measurement .....	2
1.2.2 Water level measurement principle .....	3
1.2.3 Flow measurement principle .....	3
1.3 Specifications .....	4
1.3.1 Equipment Features .....	4
1.3.2 Electrical characteristics .....	4
1.3.3 Pin Configuration .....	4
<b>2 Communication Protocol .....</b>	<b>6</b>
2.1 Modbus-RTU protocol .....	6
2.1.1 Modbus-RTU transmission mode .....	6
2.1.2 Modbus-RTU Data model .....	6
2.1.3 Modbus-RTU Common function code .....	7
2.1.4 Cyclic redundancy check (CRC) .....	8
2.1.5 Communication abnormal response .....	10
2.1.6 Terminating resistor .....	11
<b>3 Installation and Commissioning .....</b>	<b>12</b>
<b>3.1 Installation Instructions .....</b>	<b>12</b>
3.1.1 Instrument Structure .....	12
3.1.2 Appearance of instrument .....	12
3.1.3 On-site installation .....	13
3.2 Equipment debugging .....	15
3.2.1 Device address .....	15
3.2.2 Canal shape .....	16
3.2.3 River type .....	22
3.2.4 Noise threshold .....	23
3.2.5 Anemometer radar wave direction .....	23
3.2.6 Filtering times .....	24
3.2.7 measure time .....	24
3.2.8 Measurement results .....	24
3.2.9 Sleep mode .....	27
<b>4 Register list .....</b>	<b>28</b>
<b>5 Technical Parameters .....</b>	<b>32</b>
<b>6 Warranty .....</b>	<b>33</b>
6.1 warranty period .....	33
6.2 Warranty .....	33
<b>7. Appendix A FAQ .....</b>	<b>34</b>

## 1 Product Introduction

### 1.1 Product Introduction



MRCM600 radar flow meter can continuously measure the velocity, water level and flow. It uses radar planar microwave technology in a non-contact manner. According to the built-in software algorithm, calculate and output the instantaneous cross-sectional flow and accumulated flow, and at the same time, it can output the flow velocity and water level, easily connect to the telemetry platform and view the measurement information on the cloud platform. Support digital (RS485, RS232) or analog (4-20mA) transmission of measurement results, using standard ModbusRTU protocol. Support 4G, NBIoT, and LoRa technologies for wireless data transmission (optional). This product can be used for non-contact flow measurement in open channels, river channels, irrigation channels, underground drainage pipe networks, flood prevention and other occasions; this product has the characteristics of low power consumption, small size, high reliability, simple operation, convenient maintenance, etc.; measurement process Not affected by temperature, air pressure, sediment, dust, river pollutants, floating objects on the water, air and other environmental factors.

### 1.2 Measurement principle

MRCM600 radar flowmeter uses planar microwave technology, uses the principle of Doppler radar to measure the surface velocity of water flow, and uses the built-in microstrip radar technology to measure the water level. According to the velocity-area method, the measured water level is used to convert the cross-sectional area, and then the surface velocity is combined with the cross-section parameters to calculate the average velocity. The empirical formulas for the cross-section velocity distribution of open channels such as circles, rectangles, and trapezoids are established and combined with the hydraulic model algorithm. Take flow; it is a non-contact flow measuring instrument that accurately measures the flow without changing the boundary conditions of channels, rivers, pipes, etc.

### 1.2.1 Principle of flow velocity measurement

The radar flow meter uses the principle of Doppler radar speed measurement. When measuring the speed of the water surface, the radar velocity sensor emits microwaves to the water surface. After encountering the water surface, the microwaves will be absorbed and reflected. A part of the reflected wave is received by the flowmeter probe, and then converted into an electrical signal. The Doppler frequency shift is processed by the measurement circuit, and then the water flow velocity can be calculated by using a signal processing algorithm such as FFT according to the above principle.

The principle of Doppler velocimetry is as follows: When the radar wave transmitting source and the target are relatively stationary, the receiving frequency and the transmitting frequency are equal:

$$f_R = f_0 = \frac{c_0}{\lambda} \quad 1.1$$

When the position of the transmitting wave source is fixed and the moving target moves in the direction of the wave source relative to the transmitting wave source, the speed of the

radar wave for the moving target increases to  $c_0 + v$ , and the number of wavelengths of the radar wave reaching the moving target in a unit time is the receiving frequency. for:

$$f'_R = \frac{c_0 + v}{\lambda} \quad 1.2$$

Doppler shift:

$$f_D = f'_R - f_0 \quad 1.3$$

Movement speed of the moving target:

$$v = f_D \cdot \lambda = \frac{f_D}{f_0} \cdot c_0 \quad 1.4$$

When the value is positive, it means that the speed is in the same direction as the transmitted wave, and the negative sign is in the reverse direction; the speed of the moving target is proportional to the frequency shift, then:

$$v = \left( \frac{f'_R}{f_0} - 1 \right) \cdot c \quad 1.5$$

When measuring the speed of the river water surface, the radar velocity sensor emits microwaves to the water surface. After encountering water waves, blisters, and floating objects (measured moving targets), the microwaves will be absorbed and reflected, and a part of the reflected waves will be received and converted by the probe. The electrical signal is processed by the measurement circuit and the Doppler frequency shift is measured, and then the flow velocity of the water body can be calculated through the FFT floating-point operation according to the above principle. Because the radar wave emission direction and the direction of the water current usually have a certain angle, and the simultaneous transmission and reception requires a distance back and forth, the above results need to be corrected. The corrected actual water flow speed is ( $\alpha$  represents the radar wave emission direction and the horizontal direction angle):

$$v = \frac{1}{2} \left( \frac{f'_R}{f_0} - 1 \right) \cdot c_0 / \cos \alpha \quad 1.6$$

According to the above formula, the velocity of the water body can be obtained.

**1.2.2 Water level measurement principle**

The water level adopts FMCW modulation, and the triangle wave is used as the modulation signal. The working process is as follows: first, the voltage modulation circuit generates a triangular wave voltage and inputs it to a VCO (voltage-controlled oscillator) to generate electromagnetic waves with a frequency change. The frequency of the electromagnetic wave changes according to the modulation voltage law. The electromagnetic waves emitted by the antenna are reflected back after being reflected by the measured object. Waves, electromagnetic waves from the beginning to the target, reflected by the target and then returned to the antenna within the time period of the radar transmission frequency has changed, the radar antenna couples the echo signal with the transmitted signal to obtain the difference frequency signal, the target's distance and speed information It is included in the frequency of the difference frequency signal. Because the difference frequency signal is very weak, it is processed by the pre-amplification and filtering circuit of the radar sensor, and the signal is sent to the ADC (analog-to-digital converter) of the MCU. The MCU analyzes the ADC collected by the FFT algorithm. The frequency of the difference frequency is obtained from the waveform. Finally, the distance from the measured target to the sensor is calculated by the derived formula.

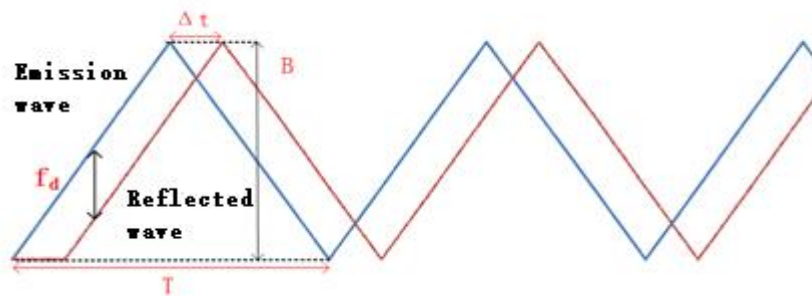

When the radar wave transmitting source and target are relatively stationary, the radar transmitting frequency bandwidth is B, the time from when the radar wave is transmitted back to the radar antenna is  $\Delta t$ , the frequency of the triangular wave is f, and the frequency of the difference frequency signal is  $f_d$ . Derived as follows: (S: distance from radar board to target, T: period of triangle wave)

$$\Delta t = \frac{2S}{c_0}$$

$$T = \frac{1}{2f}$$

$$S = \frac{f_d c_0}{4fB}$$

In the above formula,  $c_0$  is the speed of light, f is the frequency of the modulated triangle wave, B is the radar sweep frequency bandwidth, and  $f_d$  is the difference frequency signal obtained by the MCU analysis, so the only  $f_d$  can calculate the distance between the radar board and the target.

**1.2.3 Flow measurement principle**

The average velocity can be obtained and converted by the radar velocity probe, and the water depth can be obtained and converted by the radar water level probe. The cross-

sectional flow is equal to the average velocity  $\times$  the cross-sectional area of the current  $\times$  the bank coefficient. Among the open channels in the irrigation area, the common types of open channel sections in the irrigation area are rectangular, trapezoidal, or U-shaped; commonly used slopes are dry and branch canal longitudinal slopes; and two commonly used roughness ratios are concrete canal walls and masonry canal walls. For these common open channels, the bottom slope and roughness are determined. In the flow velocity distribution of the section, the flow velocity has a strong symmetry, and the straight section of the irrigation section and the downstream section are longer, and the section is symmetrical to the left and right. The distribution has the characteristics of good symmetry. Correct the velocity field distribution according to the profile, bottom (longitudinal) slope and roughness; the turbulence mathematical model used is mainly RNG (renormalized group)  $\kappa$ - $\epsilon$  model, with high calculation accuracy, good numerical stability, and calculated data Moderate.

### **1.3 Specifications**

#### **1.3.1 Equipment Features**

1. Small size, high reliability, simple operation and easy maintenance;
2. Not affected by environmental factors such as temperature, sediment, dust, river pollutants, floating objects on the water surface, and air pressure;
3. It is used for non-contact flow measurement in open channels, river channels, irrigation channels, underground drainage pipe networks, flood prevention, etc.
4. Non-contact measurement method, convenient measurement and no pollution to the environment;
5. with rain mode, to prevent interference caused by rain;
6. waterproof grade IP68, effectively prevent the internal components from getting wet;
7. low power consumption, can use solar power, easy installation and maintenance-free.

#### **1.3.2 Electrical characteristics**

1. Wide power supply voltage facilitates the selection of power supply modes;
2. The working current and standby current are low, which can be powered by solar energy, which is convenient for installation and maintenance-free;
3. Lightning protection circuit, can protect 6KV from lightning. Lightning can effectively protect the equipment from lightning strikes;
4. High test accuracy and stable data. Effectively guarantee the accuracy of the test;
- 5, support RS485, RS232, 4-20mA and other wired communication methods;
6. Support 4G, NB-IOT, Lora and other wireless communication methods (built-in optional).

#### **1.3.3 Pin Configuration**

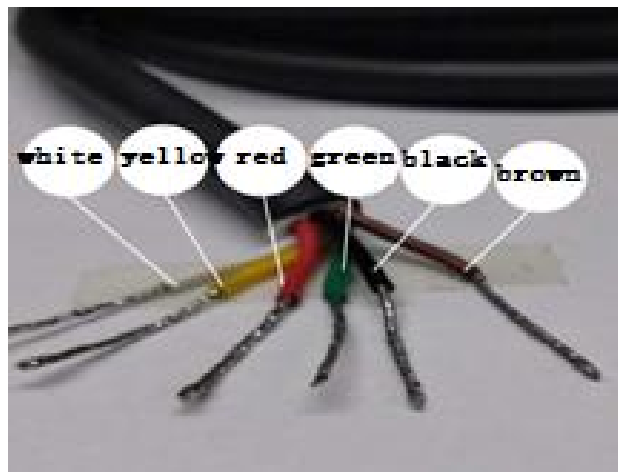
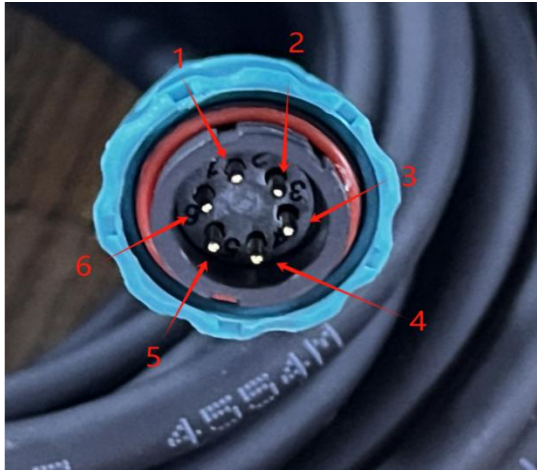

1	Brown	Power supply
2, 6	Black,White	GND
3	Green	TXD_A(232_TX/485_A+)
4	Red	RXD_B(232_RX/485_B-)
5	Yellow	IOOUT(4-20mA positive, reserved)

## 2 Communication Protocol

### 2.1 Modbus-RTU protocol

The communication method of Modbus protocol is single master / multiple slave. Only the master can issue queries (inquiries). The slave station performs the processing required by the query and responds with a response message.

#### 2.1.1 Modbus-RTU transmission mode

When the device uses RTU (Remote Terminal Unit) mode to communicate on a Modbus serial link, each 8-bit byte in the message contains two 4-digit hexadecimal characters. The main advantage of this mode is higher data density and higher throughput than ASCII mode at the same baud rate. Each message must be transmitted as a continuous character stream.

Frame description:

Device address	Function code	Data	CRC
1 byte	1byte	0~252byte	2 byte CRC low CRC high

Message frames are distinguished by an idle interval of at least 3.5 characters in time, called t3.5. This module uses the standard t3.5 as the idle interval to distinguish. The RTU frame transmission idle interval is as follows

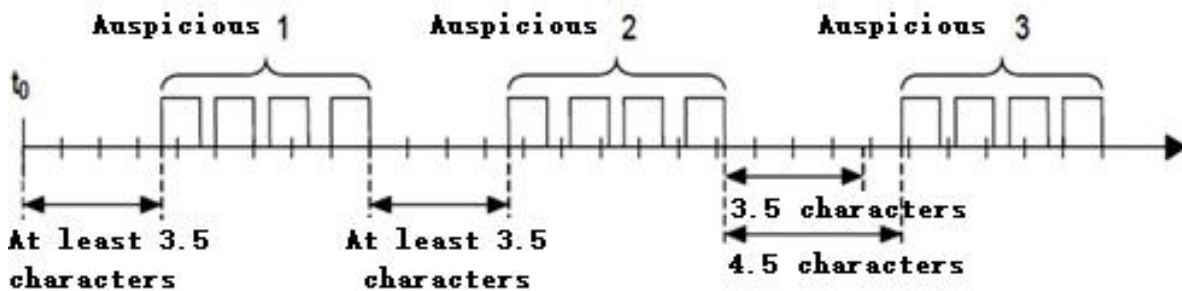

If the idle interval between two characters is greater than 1.5 character time, the message frame is considered incomplete and should be discarded by the receiving node. This idle time is called t1.5, and this module uses the standard t1.5 time. RTU frame transmission determines the abnormal frame idle interval as shown below

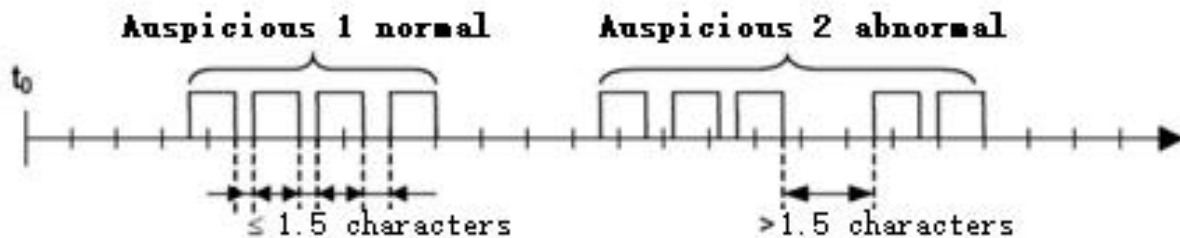

#### 2.1.2 Modbus-RTU Data model

Modbus is based on a series of data models with different characteristics. The two basic models used by the equipment are as follows:

Register type	Object type	Access type	Content
Input register	16-Bit word	Read-only	I / O system provides this type of data
Holding register	16-Bit word	Read and write	Change this type of data through the application

2.1.3 Modbus-RTU Common function code

Function Code Name	Function Code
Read input register	0x04
Read holding register	0x03
Write a single holding register	0x06
Write multiple holding registers	0x10

2.1.3.1 Read holding register (0x03)

Read holding register 0x001B Current value of baud rate.

Request message

Slave Address	Function Code	Register address	Number of registers	CRC Check value
80	03	00 1B	00 01	EA 1C

Response message

Slave Address	Function Code	Number of bytes	Register value	CRC Check value
80	03	02	00 01	45 9A

The current baud rate value 1 (9600bps)。

2.1.3.2 Read input register (0x04)

Read input register 0x000D.

Request message

Slave Address	Function Code	Register address	Number of registers	CRC Check value
80	04	00 0D	00 01	BE 18

Response message

Slave Address	Function Code	Number of bytes	Register value	CRC Check value
---------------	---------------	-----------------	----------------	-----------------

80            04            02                    00 78            85 0C

The current input voltage value 0x0078 (0x0078/10=12V)。

### 2.1.3.3 Write a single holding register (0x06)

Set the holding register 0x001B in slave address 0x80, and the baud rate is 0x01 (9600bps).

Request message

Slave Address	Function Code	Register address	Register value	CRC Check value
80	06	00 1B	00 01	26 1C

Response message

Slave Address	Function Code	Number of bytes	Register value	CRC Check value
80	06	00 1B	00 01	26 1C

### 2.1.3.4 Write multiple holding registers (0x10)

Set the shape of the holding register 0x000F in the slave address 0x80 to 0x01 (round), the distance from the holding register 0x0010 to the bottom of the canal is 0x64 (1.0m), and the holding register 0x0011 radius of the round canal is 0x64 (1.0m)

Request message

Slave Address	Function Code	Starting Address	Number of registers	Number of bytes	Register value	CRC Check value
80	10	00 0F	00 03	06	00 01 00 64 00 64	56 04

Response message

Slave Address	Function Code	Starting Address	Number of registers	CRC Check Value
80	10	00 0F	00 03	AE 1A

### 2.1.4 Cyclic redundancy check (CRC)

CRC is the most commonly used error check code in the field of data communication, which is characterized in that the length of the information field and the check field can be arbitrarily selected (using the CRC-16 check code agreed by the standard modbus).

#### Use of CRC-16 check code:

According to the Modbus protocol, the information transmission form of the conventional 485 communication is as follows:

Address	Function Code	Data Information	CRC Check Value
---------	---------------	------------------	-----------------

1byte

1byte

nbyte

2byte

The CRC check is the check value of the contents of the previous sections of data. It is a 16-bit data. When sending, the lower 8 bits are first and the upper 8 bits are last.

The receiver uses the same calculation method to calculate the check code of the information field, and compares the actual check code received. If they are equal, the information is correct;

#### CRC-16 Check code calculation method:

\*pucFrame The first address of the data to be verified, usLen is the length of the data to be verified. The return value is the check result.

```
USHORT usMBCRC16( UCHAR * pucFrame, USHORT usLen )
```

```
{
    UCHAR ucCRCHi = 0xFF;
    UCHAR ucCRCLo = 0xFF;
    int iIndex;
    while( usLen-- )
    {
        iIndex = ucCRCLo ^ *( pucFrame++ );
        ucCRCLo = ( UCHAR )( ucCRCHi ^ aucCRCHi[iIndex] );
        ucCRCHi = aucCRCLo[iIndex];
    }
    return ( USHORT )( ucCRCHi << 8 | ucCRCLo );
}
```

```
static const UCHAR aucCRCHi[] = {
    0x00, 0xC1, 0x81, 0x40, 0x01, 0xC0, 0x80, 0x41, 0x01, 0xC0, 0x80, 0x41,
    0x00, 0xC1, 0x81, 0x40, 0x01, 0xC0, 0x80, 0x41, 0x00, 0xC1, 0x81, 0x40,
    0x00, 0xC1, 0x81, 0x40, 0x01, 0xC0, 0x80, 0x41, 0x01, 0xC0, 0x80, 0x41,
    0x00, 0xC1, 0x81, 0x40, 0x00, 0xC1, 0x81, 0x40, 0x01, 0xC0, 0x80, 0x41,
    0x00, 0xC1, 0x81, 0x40, 0x01, 0xC0, 0x80, 0x41, 0x01, 0xC0, 0x80, 0x41,
    0x00, 0xC1, 0x81, 0x40, 0x01, 0xC0, 0x80, 0x41, 0x00, 0xC1, 0x81, 0x40,
    0x00, 0xC1, 0x81, 0x40, 0x01, 0xC0, 0x80, 0x41, 0x00, 0xC1, 0x81, 0x40,
    0x01, 0xC0, 0x80, 0x41, 0x01, 0xC0, 0x80, 0x41, 0x00, 0xC1, 0x81, 0x40,
    0x00, 0xC1, 0x81, 0x40, 0x01, 0xC0, 0x80, 0x41, 0x01, 0xC0, 0x80, 0x41,
    0x00, 0xC1, 0x81, 0x40, 0x01, 0xC0, 0x80, 0x41, 0x01, 0xC0, 0x80, 0x41,
    0x00, 0xC1, 0x81, 0x40, 0x00, 0xC1, 0x81, 0x40, 0x01, 0xC0, 0x80, 0x41,
    0x01, 0xC0, 0x80, 0x41, 0x00, 0xC1, 0x81, 0x40, 0x01, 0xC0, 0x80, 0x41,
    0x00, 0xC1, 0x81, 0x40, 0x00, 0xC1, 0x81, 0x40, 0x01, 0xC0, 0x80, 0x41,
    0x00, 0xC1, 0x81, 0x40, 0x01, 0xC0, 0x80, 0x41, 0x01, 0xC0, 0x80, 0x41,
```

```

    0x00, 0xC1, 0x81, 0x40, 0x01, 0xC0, 0x80, 0x41, 0x00, 0xC1, 0x81, 0x40,
    0x00, 0xC1, 0x81, 0x40, 0x01, 0xC0, 0x80, 0x41, 0x01, 0xC0, 0x80, 0x41,
    0x00, 0xC1, 0x81, 0x40, 0x00, 0xC1, 0x81, 0x40, 0x01, 0xC0, 0x80, 0x41,
    0x00, 0xC1, 0x81, 0x40, 0x01, 0xC0, 0x80, 0x41, 0x01, 0xC0, 0x80, 0x41,
    0x00, 0xC1, 0x81, 0x40
};
static const UCHAR aucCRCLo[] = {
    0x00, 0xC0, 0xC1, 0x01, 0xC3, 0x03, 0x02, 0xC2, 0xC6, 0x06, 0x07, 0xC7,
    0x05, 0xC5, 0xC4, 0x04, 0xCC, 0x0C, 0x0D, 0xCD, 0x0F, 0xCF, 0xCE, 0x0E,
    0x0A, 0xCA, 0xCB, 0x0B, 0xC9, 0x09, 0x08, 0xC8, 0xD8, 0x18, 0x19, 0xD9,
    0x1B, 0xDB, 0xDA, 0x1A, 0x1E, 0xDE, 0xDF, 0x1F, 0xDD, 0x1D, 0x1C, 0xDC,
    0x14, 0xD4, 0xD5, 0x15, 0xD7, 0x17, 0x16, 0xD6, 0xD2, 0x12, 0x13, 0xD3,
    0x11, 0xD1, 0xD0, 0x10, 0xF0, 0x30, 0x31, 0xF1, 0x33, 0xF3, 0xF2, 0x32,
    0x36, 0xF6, 0xF7, 0x37, 0xF5, 0x35, 0x34, 0xF4, 0x3C, 0xFC, 0xFD, 0x3D,
    0xFF, 0x3F, 0x3E, 0xFE, 0xFA, 0x3A, 0x3B, 0xFB, 0x39, 0xF9, 0xF8, 0x38,
    0x28, 0xE8, 0xE9, 0x29, 0xEB, 0x2B, 0x2A, 0xEA, 0xEE, 0x2E, 0x2F, 0xEF,
    0x2D, 0xED, 0xEC, 0x2C, 0xE4, 0x24, 0x25, 0xE5, 0x27, 0xE7, 0xE6, 0x26,
    0x22, 0xE2, 0xE3, 0x23, 0xE1, 0x21, 0x20, 0xE0, 0xA0, 0x60, 0x61, 0xA1,
    0x63, 0xA3, 0xA2, 0x62, 0x66, 0xA6, 0xA7, 0x67, 0xA5, 0x65, 0x64, 0xA4,
    0x6C, 0xAC, 0xAD, 0x6D, 0xAF, 0x6F, 0x6E, 0xAE, 0xAA, 0x6A, 0x6B, 0xAB,
    0x69, 0xA9, 0xA8, 0x68, 0x78, 0xB8, 0xB9, 0x79, 0xBB, 0x7B, 0x7A, 0xBA,
    0xBE, 0x7E, 0x7F, 0xBF, 0x7D, 0xBD, 0xBC, 0x7C, 0xB4, 0x74, 0x75, 0xB5,
    0x77, 0xB7, 0xB6, 0x76, 0x72, 0xB2, 0xB3, 0x73, 0xB1, 0x71, 0x70, 0xB0,
    0x50, 0x90, 0x91, 0x51, 0x93, 0x53, 0x52, 0x92, 0x96, 0x56, 0x57, 0x97,
    0x55, 0x95, 0x94, 0x54, 0x9C, 0x5C, 0x5D, 0x9D, 0x5F, 0x9F, 0x9E, 0x5E,
    0x5A, 0x9A, 0x9B, 0x5B, 0x99, 0x59, 0x58, 0x98, 0x88, 0x48, 0x49, 0x89,
    0x4B, 0x8B, 0x8A, 0x4A, 0x4E, 0x8E, 0x8F, 0x4F, 0x8D, 0x4D, 0x4C, 0x8C,
    0x44, 0x84, 0x85, 0x45, 0x87, 0x47, 0x46, 0x86, 0x82, 0x42, 0x43, 0x83,
    0x41, 0x81, 0x80, 0x40};

```

### 2.1.5 Communication abnormal response

When the master device sends a request to the slave device, the master wants to get a normal response. Interrogation by the master can cause one of four events:

---- If the slave device receives the request without communication error and can process the query normally, then the slave device will return a normal response.

---- If the slave does not receive the request due to a communication error, it cannot return a response. The master program will be processed as a timeout.

---- If the slave receives the request, but detects a communication error (parity, CRC ...), then it cannot return a response. The master program will handle it as a timeout.

---- If the slave device receives a request without a communication error, but cannot process the request (for example, if the request reads a non-existent input register), then the slave will return an exception response to notify the client of an error. the reason.

The abnormal response message has two different fields from the normal response message:

Function code field: In the normal response, the slave station responds with the function code field to assign the function code of the original request. All function codes have MSBs

of 0 (their values are all lower than 80 hex). In the abnormal response, the slave sets the MSB of the function code to 1. This causes the function code value in the abnormal response to be hex 80 higher than the function code value in the normal response. By setting the function code MSB, the application of the master station can recognize the abnormal response and can detect the data field of the abnormal code. Data field: In a normal response, the slave can return data or statistical values (any information requested in the request) in the data field.

In the exception response, the slave returns an exception code in the data field. This explains the cause of the exception. The exception response message for all supported function codes is the function code plus 0x80.

All exception function codes are 0x83, 0x84, 0x86, 0x88, 0x90, 0x97.

The exception response message corresponding to function code 0x06 is as follows:

Slave Address	Function Code	Exception Code	CRC Check Value
80	86	01	3D 88

Exception code	Exception Name	Description
01	Illegal Function Code	Function code cannot be identified, not within 0x00 ~ 0x0F
02	Illegal data address	Data address exceeds definition
03	Illegal data value	Values outside register storage
04	Slave device failure	Produces an unrecoverable error

**2.1.6 Terminating resistor**

During the network construction process, if the network terminates the embedded connection with other Modbus devices, you need to connect a 120 ohm terminal matching resistor at the end of the network (for RTUs that have integrated matching resistors internally, they can be omitted).

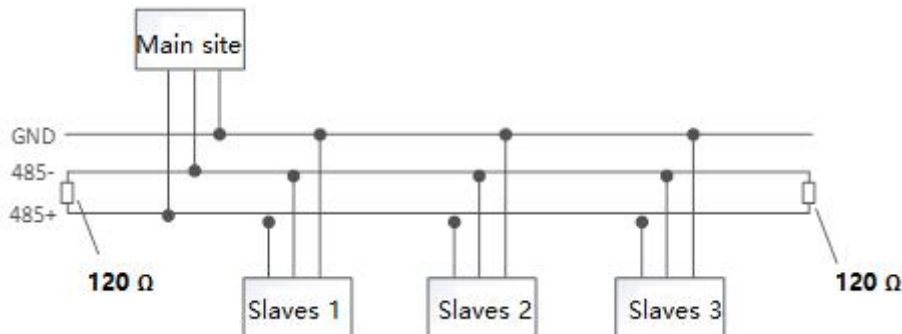

### 3 Installation and Commissioning

#### 3.1 Installation Instructions

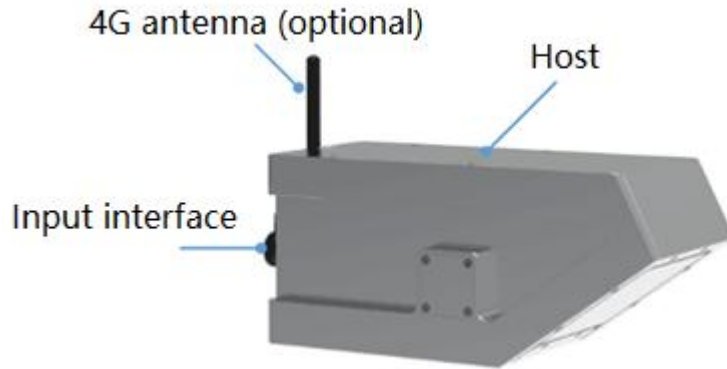

##### 3.1.1 Instrument Structure

As shown in the figure above, the flowmeter host consists of a flow velocity measurement sensor, a water level measurement sensor, a data transmission interface, and a wireless data transmission antenna (optional).

##### 3.1.2 Appearance of instrument

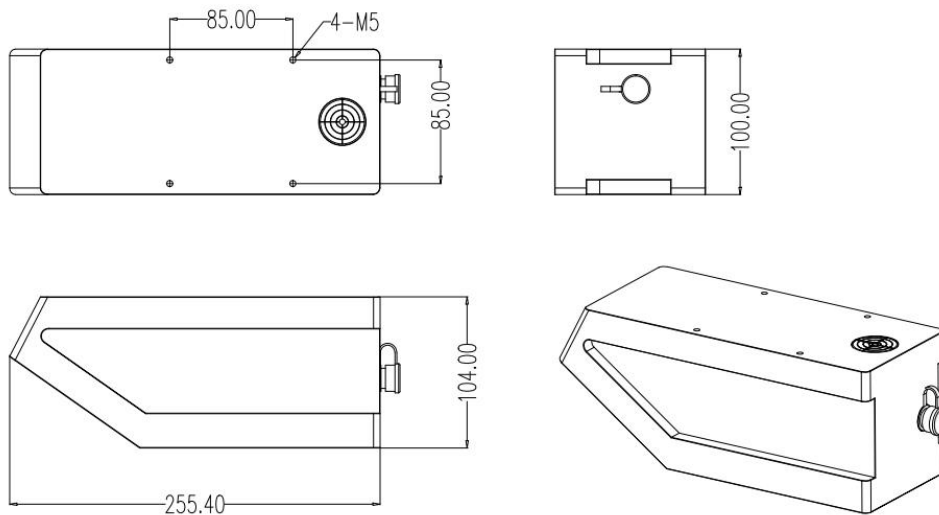

MRCM600 Dimension

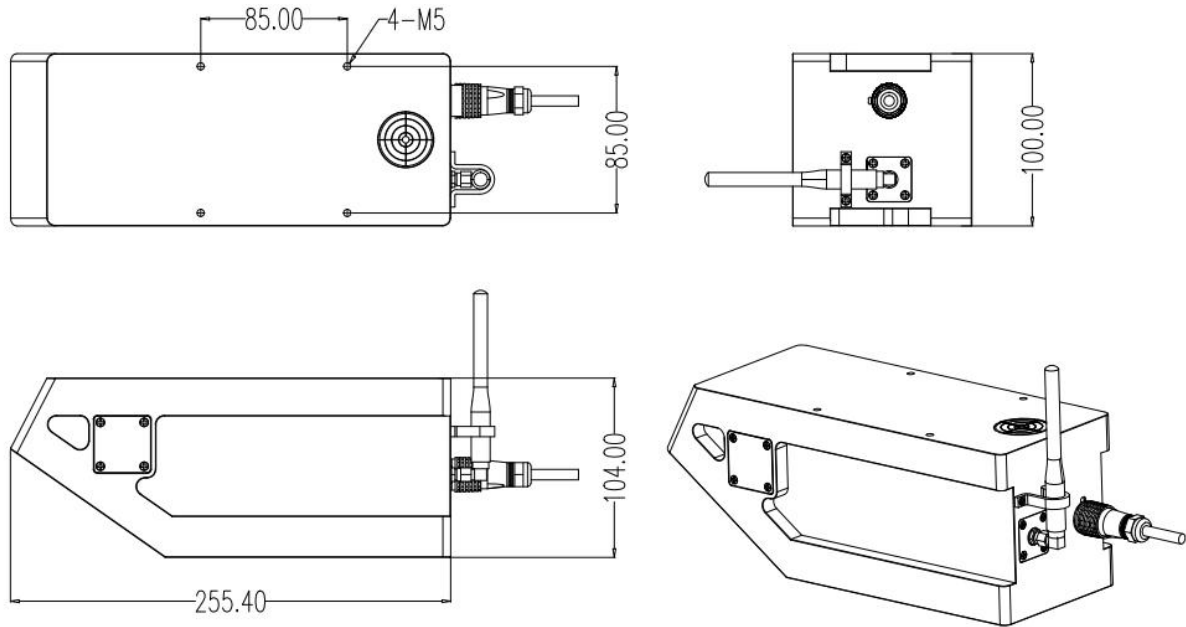

MRCM600-R dimension

### 3.1.3 On-site installation



The installation direction is shown in the figure above. Three clamps fix the bracket and the instrument on the crossbar (crossbar diameter range: 40mm-85mm). Keep the upper surface of the instrument and the river level during installation (Note: the bubble of the leveler is adjusted to the center). Direction suggestion: The direction of water flow relative to the velocity measurement is oncoming.

#### 3.1.3.2 Measurement point selection

When selecting the installation site, ensure that the radar waves cover the water surface, avoid the effects of floating objects, vortices and aquatic plants, and also avoid river bed sedimentation in the low water period, the main groove swing, etc. causing the radar waves to cover the ground and make measurement errors. The radar water level gauge has an emission angle of  $12^\circ$ , and the coverage range is approximately circular; the radar flow meter has an emission angle of  $12^\circ$ , and the coverage range is approximately elliptical as shown in the figure below;

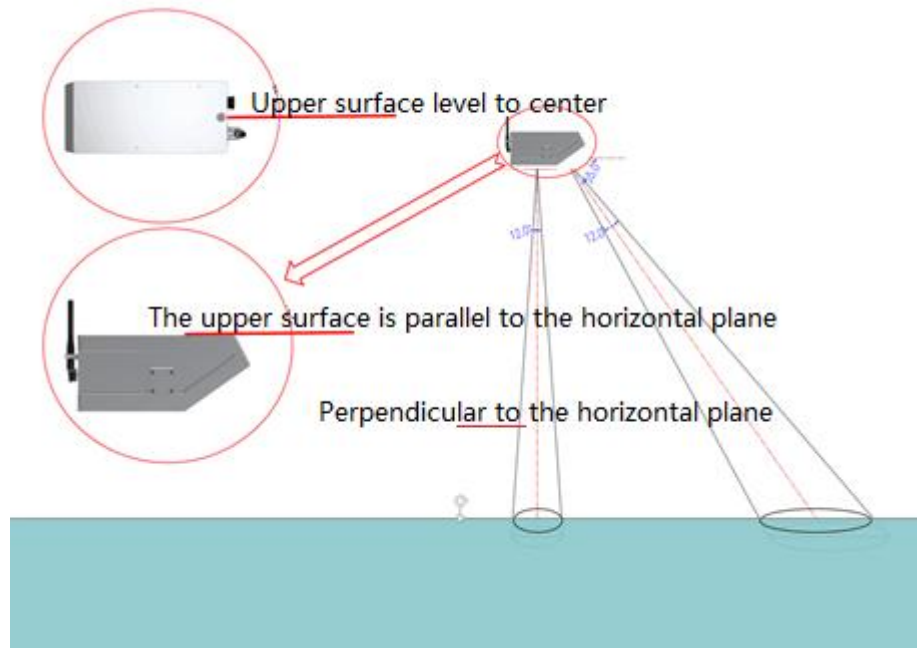

The relationship between the diameter and distance of a circle is shown in the following table:

Installation height (m)	Velocity meter covers diameter range (m)	Water level gauge covers diameter range (m)
5	1.994	1.051
10	3.977	2.102
15	5.960	3.153
20	7.943	4.204
25	9.925	5.255
30	11.994	6.036
35	13.891	7.357
40	15.874	8.408

**The selection of channel measurement points should follow the following main principles:**

- 1) The channel is straight, the channel foundation is fixed, and the cross section is stable, which is convenient for equipment installation;
- 2) The water flow is smooth and even, and it is not affected by the vortex, the opening and closing of the gate and the backwater of the canal system
- 3) The measurement section is perpendicular to the direction of the water flow;
- 4) There should be no buildings, trees or weeds affecting the flow near the cross section, and they will not be affected by the discharge when the buildings are downstream;
- 5) It should not be set up in a place where the sedimentation is serious and there are many waterweeds or debris.

For non-contact measurement equipment such as radar flowmeters, the installation points should be avoided as follows

- 1) Avoid places where the direction of the river or channel water flow changes, and try to ensure that the water flow direction is parallel to the radar flowmeter installation direction;

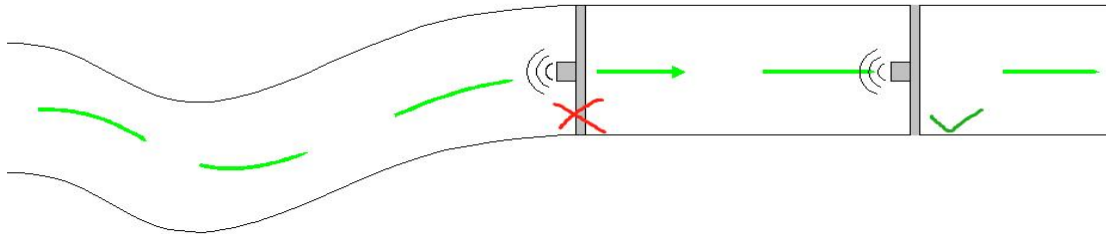

- 2) Avoid the direction of the flow rate probe of the radar meter facing the large drop current;

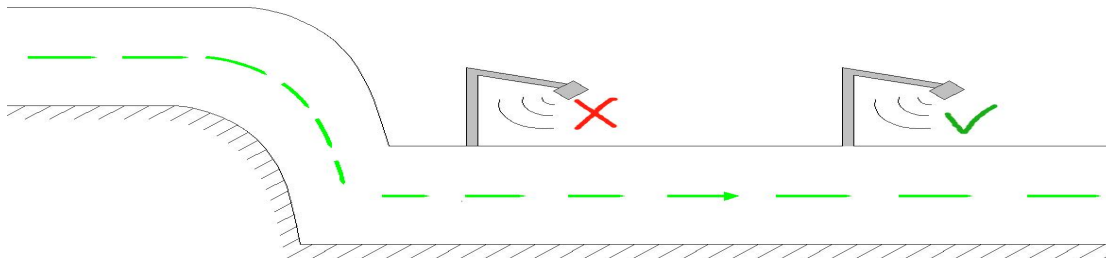

- 1) Avoid installation above the gate and above the cistern with undercurrent. The typical feature of this scenario is the lowering of the water level, but the undercurrent under the water surface cannot cause a stable flow velocity on the surface and is not suitable for the installation point;

- 2) Avoid installation points located at the exit of culverts, mountain pass air ducts, etc., where wind is likely to rise. Wind has a certain effect on low flow velocity measurement.

### 3.1.3.3 Precautions

1. When the instrument is installed, the upper surface and the river surface should be kept level;
2. Do not install the instrument on the turn;
3. Do not install the instrument in the place of high and low drop;
4. Do not install the instrument on the surface of water with vortex.

## 3.2 Equipment debugging

### 3.2.1 Device address

The device address can be set from 1 to 200 by setting the value of the holding register address 0x001C. The factory default slave address is 0x80. After the slave address is set successfully, it will be saved automatically.

Example of setting the device address to 0x01

Request message sent

Slave address	function code	Register address	Register value	CRC Check value
80	06	00 1C	00 01	97 DD

Response message

Slave address	function code	Register address	Register value	CRC Check value
80	06	00 1C	00 01	97 DD

When you forget the device address, you can specify the device address as 0xFF, and query the register address 0x001C through the Modbus protocol 03 function code to obtain the real address of the device.

**Note: When using this method to query the device address, only one device can be connected to the 485 bus.**

Example of device address query

Request message sent

Slave address	function code	Register address	Register value	CRC Check value
FF	03	00 1C	00 01	50 12

Response message

Slave address	function code	Number of bytes	Register value	CRC Check value
80	03	02	00 80	85 FA

The register value 0x0080 in the response message is the real device address of the device.

### 3.2.2 Canal shape

The device supports three basic types of canal shapes: circular, trapezoidal and U-shaped. By adjusting the length of the bottom and top sides of the trapezoid, rectangular and triangular canals can be obtained. Channel parameters support Modbus protocol 0x06 and 0x10 function code settings, and 0x03 function code reading. Set the channel shape register to 0x000F. The values are as follows:

Register value	description
----------------	-------------

0x01	Round
0x02	Trapezoid
0x03	U type

**3.2.2.1 Round canal**

The parameters that need to be set for the circular canal are the shape of the canal, the distance from the radar flow meter to the bottom of the canal, and the radius of the circular canal. The distance from the radar flow meter to the bottom of the canal and the radius of the circular canal need to be enlarged by 100 times the actual value. The value written in m is 123. Note that the decimal value needs to be converted into hexadecimal and brought in (123 corresponds to 7B in hexadecimal).

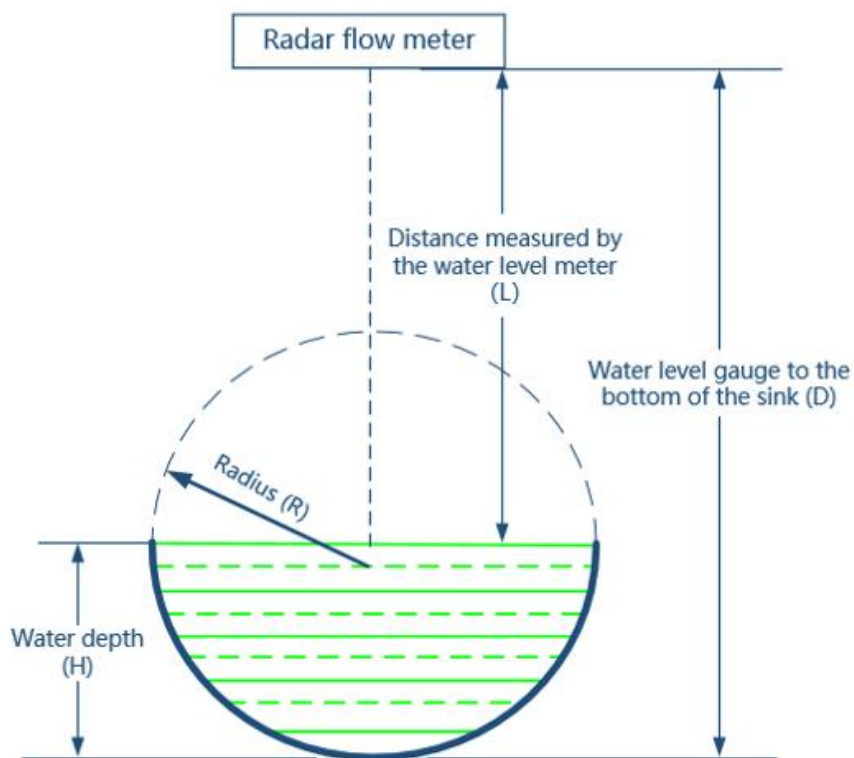

Holding register address corresponding to circular channel parameter

Function	Register address	Number of registers
Canal shape	0x000F	1
Distance from the water level gauge to the bottom of the canal	0x0010	1

Round canal radius                      0x0011                      1

Example of setting circular channel parameters

Set the shape of the canal to a circle and send a request message (the response message is the same as the request message)

Slave address	function code	Register address	Register value	CRC Check value
80	06	00 0F	00 01	66 18

Set the distance from the water level meter to the bottom of the canal to 1.0m in decimal (100 times magnification is 100, which is equal to 0x64 in hexadecimal), and send the request message (the response message is the same as the request message)

Slave address	function code	Register address	Register value	CRC Check value
80	06	00 10	00 64	97 F5

Set the circular canal radius to 1.0m and send the request message (the response message is the same as the request message)

Slave address	function code	Register address	Register value	CRC Check value
80	06	00 11	00 64	C6 35

### 3.2.2.2 Trapezoidal canal

The parameters required for the trapezoidal canal are the shape of the canal, the distance from the radar flow meter to the bottom of the canal, the length of the bottom of the trapezoidal canal, the length of the top of the trapezoidal canal, and the height of the trapezoidal canal. The distance from the radar flow meter to the bottom of the canal, the length of the bottom edge of the trapezoidal canal, the length of the top edge of the trapezoidal canal, and the height of the trapezoidal canal need to be enlarged by 100 times. If the actual value is 1.23m, the value written is 123. Note that The decimal value is converted into hexadecimal and brought in (123 corresponds to 7B in hexadecimal).

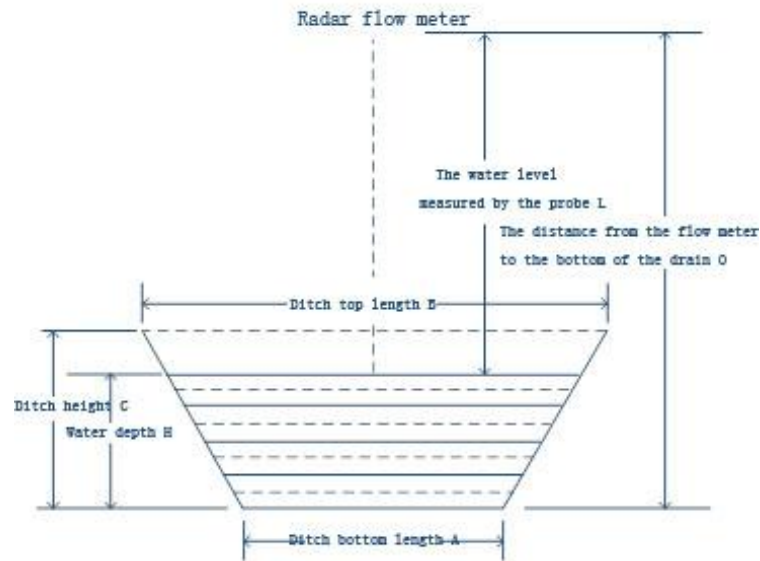

Holding register address corresponding to the trapezoidal channel parameter

function	Register address	Number of registers
Canal shape	0x000F	1
Distance from the radar flow meter to the bottom of the canal	0x0010	1
Length of bottom of trapezoidal canal	0x0012	1
Top of trapezoidal canal	0x0013	1
Trapezoidal channel height	0x0014	1

Example of setting trapezoidal channel parameters

Set the channel shape to trapezoidal and send the request message (the response message is the same as the request message)

Slave address	function code	Register address	Register value	CRC Check value
80	06	00 0F	00 02	26 19

Set the distance from the radar flow meter to the bottom of the canal to 1.0m in decimal (100 times magnification is 100, which is equal to 0x64 in hexadecimal), and send the request message (the response message is the same as the request message)

Slave address	function code	Register address	Register value	CRC Check value
80	06	00 10	00 64	97 F5

Set the bottom length of the trapezoidal canal to 1.0m and send the request message (the response message is the same as the request message)

Slave address	function code	Register address	Register value	CRC Check value
80	06	00 12	00 64	36 35

Set the top edge length of the trapezoidal canal to 1.0m, and send the request message (the response message is the same as the request message)

Slave address	function code	Register address	Register value	CRC Check value
80	06	00 13	00 64	67 F5

Set the trapezoidal canal height to 1.0m and send the request message (the response message is the same as the request message)

Slave address	function code	Register address	Register value	CRC Check value
80	06	00 14	00 64	D6 34

### 3.2.2.3 U Canal

The parameters required for the U-shaped canal are the shape of the canal, the distance from the radar flow meter to the bottom of the canal, the height of the fan, the length of the bottom edge of the trapezoidal part, the length of the top edge of the trapezoidal part, and the height of the canal. The distance from the radar flow meter to the bottom of the canal, the height of the fan, the length of the bottom of the trapezoidal part, the length of the top of the trapezoidal part, and the height of the canal need to be enlarged by 100 times the actual value. If the actual value is 1.23m, the value written is 123. You need to convert the decimal value into hexadecimal and bring it in (123 corresponds to 7B in hexadecimal).

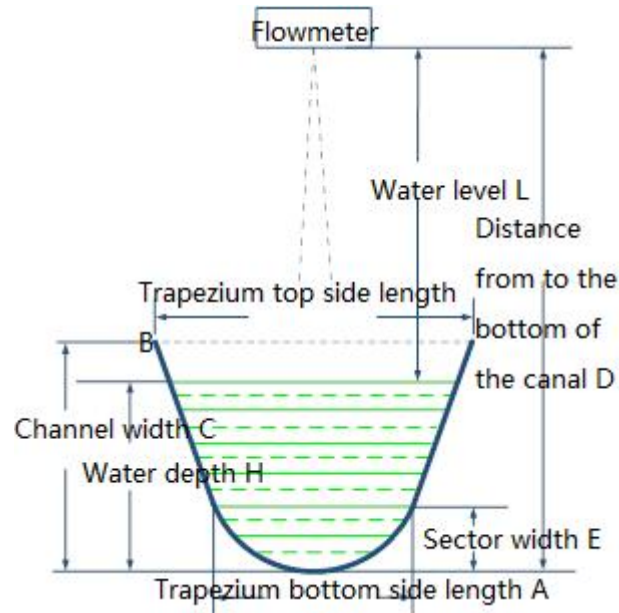

Holding register address corresponding to U-shaped channel parameter

Function	Register address	Number of registers
Canal shape	0x000F	1
Distance from the radar flow meter to the bottom of the canal	0x0010	1
Sector height	0x0011	1
Length of bottom edge of trapezoidal part	0x0012	1
Top side of trapezoidal part	0x0013	1
Canal height	0x0014	1

Example of setting U-shaped channel parameters

Set the channel shape to U-shaped, and send the request message (the response message is the same as the request message)

Slave address	function code	Register address	Register value	CRC Check value
80	06	00 0F	00 03	E7 D9

Set the distance from the radar flow meter to the bottom of the canal to 1.0m in decimal (100 times magnification is 100, which is equal to 0x64 in hexadecimal), and send the request message (the response message is the same as the request message)

Slave address	function code	Register address	Register value	CRC Check value

80                    06                    00 10                    00 64                    97 F5

Set the fan height to 1.0m, and send the request message (the response message is the same as the request message)

Slave address	function code	Register address	Register value	CRC Check value
---------------	---------------	------------------	----------------	-----------------

80                    06                    00 11                    00 64                    C6 35

Set the bottom length of the trapezoid part to 1.0m, and send the request message (the response message is the same as the request message)

Slave address	function code	Register address	Register value	CRC Check value
---------------	---------------	------------------	----------------	-----------------

80                    06                    00 12                    00 64                    36 35

Set the top edge length of the trapezoid part to 1.0m and send the request message (the response message is the same as the request message)

Slave address	function code	Register address	Register value	CRC Check value
---------------	---------------	------------------	----------------	-----------------

80                    06                    00 13                    00 64                    67 F5

Set the height of the trapezoidal part to 1.0m and send the request message (the response message is the same as the request message)

Slave address	function code	Register address	Register value	CRC Check value
---------------	---------------	------------------	----------------	-----------------

80                    06                    00 14                    00 64                    D6 34

**3.2.3 River type**

Different river types correspond to different built-in filtering schemes. In case of uncertainty, this setting can be used by default. Set the river type register to 0x0016.

Register value	description
----------------	-------------

0x01	Straight
0x02	normal type
0x03	Turbulent
0x04	Inclined
0x05	Splash type

Example of setting river type

Request message sent (response message is the same as request message)

Slave address	function code	Register address	Register value	CRC Check value
80	06	00 16	00 01	B7 DF

**3.2.4 Noise threshold**

The noise threshold is used to set the signal extraction threshold. If the signal strength of the device (obtained through the input register) is lower than the set value, the noise is not picked up. This item usually does not need to be adjusted. According to the factory default, the signal is weak when the installation distance is long and the flow rate is low. It needs to be adjusted according to the signal strength of the scene. The threshold of the flow meter is generally not lower than 400. The register that sets the flow meter noise threshold is 0x000B.

Example of setting the flow meter noise threshold to 1000

Request message sent (response message is the same as request message)

Slave address	function code	Register address	Register value	CRC Check value
80	06	00 0B	03 E8	E6 A7

**3.2.5 Anemometer radar wave direction**

Velocity meter radar wave directions are forward, countercurrent and bidirectional. The flow meter radar wave is in the same direction as the river flow (the relative flow measurement direction is away from the water flow), and the flow meter is set to collect only the downstream speed. The reverse direction of the radar wave and the river is the countercurrent (the relative velocity measurement direction is the oncoming water flow). When set to the countercurrent, the velocity meter only collects the countercurrent velocity. When set to bi-directional, the flow meter automatically recognizes the flow direction and collects the flow rate of the forward and reverse flow. It is recommended to install counter current (factory default). The counter current has anti-rain function. Set the register of the radar wave direction of the flow meter to 0x0018. The values are as follows:

Register value	description
0x01	Downstream
0x02	countercurrent
0x03	Two way

Example of setting the direction of the radar wave

Request message sent (response message is the same as request message)

Slave address	function code	Register address	Register value	CRC Check value
80	06	00 18	00 02	96 1D

**3.2.6 Filtering times**

The larger the number of filtering is, the smaller the value fluctuation is, the more stable the measurement result is, but the real-time performance is weakened. Normal default is fine. The register for setting the filtering times of the flow meter is 0x000D, and the register for setting the filtering times of the water level meter is 0x000E.

Example of setting the flowmeter filter times to 20

Request message sent (response message is the same as request message)

Slave address	function code	Register address	Register value	CRC Check value
80	06	00 0D	00 14	06 17

Example of setting the water level gauge filtering times to 5

Request message sent (response message is the same as request message)

Slave address	function code	Register address	Register value	CRC Check value
80	06	00 0E	00 05	36 1B

**3.2.7 measure time**

1. High signal strength: stable value will be measured in about 30s.
2. The signal strength is relatively weak: Although the measured result takes a long time (2min) at this time, the measurement performance for low flow rate is high at this time, and the obtained result is also stable.

**3.2.8 Measurement results**

The measurement results are stored in the holding register and the input register, which can be read through the Modbus protocol 0x03 or 0x04 function code (recommended to use the 0x04 function code to read the input register). Read the relevant register through the debugging assistant (such as MODBUS debugging assistant), please note that the value read out at this time is hexadecimal, so it needs to be converted to decimal for the convenience of calculation. For example: Now the flow rate is to be queried, then the value read from the 0x0001 register is 0x7B, and 0x7 converted to decimal is 123. At this time, the actual flow rate needs to be reduced by 1000 times (0.123m / s). It should be noted here that the values stored in the registers are all enlarged values (the description in the "Description" column in the table below refers to the values stored in the registers are enlarged), so the extracted values To reduce the corresponding multiple. (Note: the waiting time for each query command is 100ms)

**Read by 0x03 function code, the holding register address is as follows**

Flow rate	0x0001	m/s	1000 times magnified
Water level	0x0002	m	1000 times magnified
Empty height	0x0003	m	1000 times magnified
Instantaneous flow	0x0004	m <sup>3</sup> /s	1000 times magnified
Cumulative flow (higher 16 bits)	0x0005	m <sup>3</sup>	1000 times magnified after

Cumulative flow (middle 16 digits)	0x0006		merged
Cumulative flow (lower 16 bits)	0x0007		
Flow rate signal strength	0x0008	/	/
Water level signal strength (reserved)	0x0009	/	/
Flow direction	0x000A	/	Reverse: 0 Forward: 1
accident details	0x0021	/	(Reserved)
Vertical angle	0x0022	°	enlarged 100 times
Input voltage	0x0023	V	10 times magnified

**Read by 0x04 function code, the holding register address is as follows**

Flow rate	0x0001	m/s	1000x magnified
Water level	0x0002	m	1000x magnified
Empty height	0x0003	m	1000x magnified
Small Instantaneous flow	0x0004	m <sup>3</sup> /s	1000x magnified
Cumulative traffic (higher 16 bits)	0x0005		
Cumulative traffic (middle 16 bits)	0x0006	m <sup>3</sup>	1000x magnification after merging
Cumulative traffic (lower 16 bits)	0x0007		
Velocity signal intensity	0x0008	/	/
Water level signal strength (reserved)	0x0009	/	/
Flow direction	0x000A	/	Reverse is 0
accident details	0x000B	/	Forward direction is 1
Vertical angle	0x000C	°	(Reserved)
Input voltage	0x000D	V	100 times magnified
Software version number	0x000E		High 8 bit plus low 8 bit combination
Large instantaneous flow (high 16 bits)	0x000F	M <sup>3</sup> /s	1000 times magnified
Large instantaneous flow (lower 16 bits)	0x0010	M <sup>3</sup> /s	1000 times magnified

**Note: In order to deal with the decimal part, the flow rate, water level, air height, etc. are all magnified. After the value is read, it needs to be reduced. For example, if the flow rate read back is 1000, the real flow rate is 1m / s.**

Input register address 0X04 instantaneous flow only supports small flow storage, the range is 0-65.535 M<sup>3</sup> / s, if the instantaneous flow value is large, you can read registers 0x0F and 0x10, the storage range is 0-4294967.296 M<sup>3</sup> / s, when the instantaneous flow When the value is less than 65.535 M<sup>3</sup> / s, the 0x04 and 0X10 registers are equal.

Example of reading a single input register by 0x04 function code (reading flow rate)

Request message sent

Slave address	function code	starting address	Number of registers	CRC Check value
80	04	00 01	00 01	7E 1B

Response message

Slave address	function code	Number of data bytes	Register value	CRC Check value
80	04	02	00 7B	C5 0D

0x04 function code can read multiple continuous registers, read all measurement results by 0x04 function code

Request message sent

Slave address	function code	starting address	Number of registers	CRC Check value
80	04	00 01	00 0D	7E 1E

Response message

Slave address	80
function code	04
Number of data bytes	20
Velocity	01 CD
Water level	04 01
Empty height	08 75
Small Instantaneous flow	8F 34
Cumulative traffic (higher 16 bits)	00 08
Cumulative traffic (middle 16 bits)	94 4B
Cumulative traffic (lower 16 bits)	EB 6A
Velocity signal intensity	02 F7
Water level signal strength	00 00

Flow direction	00 01
accident details	02 97
Vertical angle	14 96
Input voltage	00 76
Software version number	02 04
Large instantaneous flow (high 16 bits)	00 00
Large instantaneous flow (lower 16 bits)	8F 34
CRC check value	12 34

Note: The CRC check value in the response message will change due to the actual measured value change.

### 3.2.9 Sleep mode

After setting the sleep time of the device, before entering the sleep mode, the flow meter will measure the latest flow rate, water level and other data from the time when the sleep mode was entered and save it. After the set sleep time, it will exit the sleep mode, the flow meter will be automatically awakened, and the flow meter after the wake will measure the latest flow after wake up in the shortest time (note that the accumulated flow at this time is the latest flow after wake up) The product of the measured flow and the sleep time is added to the accumulated flow before sleep).

Because there may be unpredictable flow changes during the period of dormancy, the flow velocity of the water flow during the dormant period may be unstable, and the accumulated flow rate during the dormant period may be different from the actual accumulated flow rate. In order to ensure the accuracy of the accumulated flow, it is recommended that the sleep time should not be set too long or it is best not to let the flowmeter enter the sleep or power down mode. (Remarks: Sleep time can be set)

## 4 Register list

## Holding register list

Address Hex	Name	Description	Data range	Defaults	Read and write status
1	Flow rate	Unit: m / s 1000x magnification	0~65535	0	Read-only
2	Water level	Unit: m 1000 times the water level value	0~65535	0	Read-only
3	Empty height	Unit: m 1000-fold aerial height value	0~65535	0	Read-only
4	Small Instantaneous flow	Unit: m <sup>3</sup> / s 1000 times the instantaneous flow	0~65535	0	Read-only
5	Cumulative traffic (higher 16 bits)		0~65535	0	Read-only
6	Cumulative traffic (middle 16 bits)	Unit: m <sup>3</sup> 1000 times the cumulative flow	0~65535	0	Read-only
7	Cumulative traffic (lower 16 bits)		0~65535	0	Read-only
8	Velocity signal intensity	Current signal strength	0~65535	0	Read-only
9	Water level signal strength (reserved)	Water level current signal strength	0~65535	0	Read-only
A	Flow direction	0x00: Reverse 0x01: forward	0~1	0	Read-only
B	Flow noise threshold	Set/Query the flow noise threshold	0~65535	800	Read and write
C	Water level noise threshold (reserved)	Set/Query water level noise threshold	0~65535	500	Read and write
D	Velocity filtering times	Set/Query the number of flow rate filters	1~30	20	Read and write
E	Water level filtering times	Set/Query the number of water level filters	1~30	5	Read and write
F	Canal shape	0x01: Round 0x02: trapezoid 0x03: U type	1-3	0	Read and write
10	Distance from the water level gauge to the bottom of the canal	Unit: m Support decimal, write after 100 times magnification	0~65535	0	Read and write

Address Hex	Name	Description	Data range	Defaults	Read and write status
11	Round canal radius / U-shaped canal fan height	Unit: m Support decimal, write after 100 times magnification	0~65535	0	Read and write
12	Length of bottom of trapezoidal channel U-shaped canal trapezoidal part bottom length	Unit: m Support decimal, write after 100 times magnification	0~65535	0	Read and write
13	Top of trapezoidal canal The top edge of the trapezoidal part of the U-shaped channel	Unit: m Support decimal, write after 100 times magnification	0~65535	0	Read and write
14	Trapezoidal channel height U-shaped canal height	Unit: m Support decimal, write after 100 times magnification	0~65535	0	Read and write
15	Shore factor	Instantaneous flow scale factor, default 1.0 Support decimal, write after 100 times magnification	0~65535	100	Read and write
16	River type	0x01: Straight 0x02: Normal type 0x03: Turbulent 0x04: inclined 0x05: Splash type	1~5	2	Read and write
17	Anemometer position	0x01: 1 0x02: 2 0x03: 3	1~3	2	Read and write
18	Anemometer radar wave direction	0x01: Forward 0x02: reverse 0x03: bidirectional 0x00: not limited	1~3	2	Read and write
19	Maximum flow rate	Support decimal, write after 100 times magnification	0~65535	0	Read and write
1A	Clear accumulated traffic	0x01: Clear	0~1	0	Read and write
1B	Serial baud rate	0x01: 9600 0x02: 19200 0x03: 56000 0x04: 115200	1~4	1	Read and write
1C	Device address	Set / read device address	1~200	0x80	Read and write
1D	Manual vertical angle acquisition	The device automatically acquires an angle every 20s 0x01: Manual acquisition once Unit: °	0~1	0	Read and write
1E	Horizontal angle	Manually enter horizontal angle, decimals are not supported	0~60	0	Read and write
1F	Rainy mode	0x01: turn on 0x02: close	1~2	1	Read and write

**20** Sleep time Unit: minute  
Sleep time after a single measurement cycle 0~65535 0 Read and write

Address Hex	Name	Description	Data range	Defaults	Read and write status
<b>21</b>	accident details	Reserve	-	-	-
<b>22</b>	Vertical angle	Unit: ° Vertical angle value after 100 times magnification	0~65535	0	Read-only
<b>23</b>	Input voltage	Unit: V Input voltage value after 10 times magnification	0~65535	0	Read-only
<b>24</b>	Software version number	Software version number 8-bit plus 8-bit combination For example, 0x0102 corresponds to the version number V1.2	0~65535	0	Read-only
<b>25</b>	Reset	0x01: Restore factory default settings	0~1	0	Read and write
<b>2C</b>	Still water height setting	The water level is less than this value, and the flow output is 0 Support decimal, write after 100 times magnification	0~65535	0	Read and write
<b>2D</b>	Maximum fluctuation limit	Reserve			
<b>2E</b>	4-20mA output selection	0x01: Empty height 0x02: water level	1~2	1	Read and write

## Input register list

1	Flow rate	Unit: m / s 1000x magnification	0~65535	0
2	Water level	Unit: m 1000 times the water level value	0~65535	0
3	Empty height	Unit: m 1000-fold aerial height value	0~65535	0
4	Small Instantaneous flow	Unit: m <sup>3</sup> / s 1000 times the instantaneous flow	0~65535	0
5	Cumulative traffic (higher 16 bits)		0~65535	0
6	Cumulative traffic (middle 16 bits)	Unit: m <sup>3</sup> 1000 times the cumulative flow	0~65535	0
7	Cumulative traffic (lower 16 bits)		0~65535	0
8	Velocity signal intensity	Current signal strength	0~65535	0
9	Water level signal strength (reserved)	Water level current signal strength	0~65535	0
A	Flow direction	0x00: Reverse 0x01: forward	0~1	0
B	accident details	Reserve	-	-
C	Vertical angle	Unit: ° Vertical angle value after 100 times magnification	0~65535	0
D	Input voltage	Unit: V Input voltage value after 10 times magnification	0~65535	0
E	Software version number	Software version number 8-bit plus 8-bit combination For example, 0x0102 corresponds to the version number V1.2	0~65535	0
F	Large instantaneous flow (higher 16 bits)		0~65535	0
10	Large instantaneous flow (lower 16 bits)	Unit: m <sup>3</sup> / s 1000 times the instantaneous flow	0~65535	0

**Note:** The instantaneous flow of register address 0x04 only supports the storage of small flow, the range is 0-65.535 m<sup>3</sup> / s. If the instantaneous flow value is large, you can read the registers 0x0F and 0x10, the storage range is 0- 4294967.296 m<sup>3</sup> / s. When the instantaneous flow value is less than 65.535 m<sup>3</sup> / s, the 0x04 and 0x10 register values are equal.

## 5 Technical Parameters

### Flow measurement system

Measurement principle	Planar Microstrip Array Antenna CW + FMCW
Operating mode	Manual, automatic, telemetry
Applicable environment	24 hours, rainy
Operating temperature	-35 to +70°C
Operating Voltage	7~32 V DC
Working current	12 V DC input, working mode: $\leq 35\text{mA}$ standby mode: $\leq 1\text{mA}$
Protection class	IP68
Lightning protection level	6 KV
Radar wave velocity sensor	
Radar frequency	24 GHz
Maximum range	40m
Speed measurement range	0.03~20 m/s
Speed measurement accuracy	$\pm 0.01\text{ m/s}; \pm 1\%FS$
Antenna angle	12°
Measurement direction	Automatic identification of water flow direction, built-in vertical angle correction

### Radar water level gauge

Radar frequency	80 GHz
Measuring range	40 m
Measurement accuracy	$\pm 2\text{mm}, \pm 0.05\%FS$
Antenna angle	8°

### Data transmission system

Digital transmission method	RS485 / RS232, 4-20mA, LoRa (wireless option), NB-IoT (wireless option), 4G RTU (wireless option)
-----------------------------	---

## **6 Warranty**

The supplier guarantees that the MRCM600 instrument has no defects in performance and quality when it is sold. For problems that occur during use, the company only repairs or replaces the instrument that fails under the correct conditions of use.

Before returning the instrument for repair, please contact the supplier; the returned product must be packed intact to ensure that the instrument will not be damaged due to the transportation process.

### **6.1 warranty period**

The free warranty period for users is one year (counting from the date of purchase). The company will provide paid repairs for instruments that exceed the warranty period.

### **6.2 Warranty**

During the warranty period, the company will only repair products that have failed under the correct conditions of use for free.

Failure caused by the following conditions is not covered by the warranty:

- Warranty period;
- Failure to use, maintain and cause damage as required by the product instruction manual;
- Damage caused by unauthorized removal (private removal and repair) by a repairer not authorized by the company;
- Other non-quality causes such as natural disasters and mechanical damage.

## 7. Appendix A FAQ

### **Q: Why doesn't the upper computer receive any data?**

answer:

- 1) Check if the power supply voltage is between 7 ~ 32VDC, and then power on again after confirmation;
- 2) Check if the communication method, serial port number and baud rate are correct;
- 3) Check whether the communication protocol operates according to the instructions and check whether the instructions are correct;
- 4) Try another USB to 485 communication cable and test again

### **Q: Why is the measured value always zero?**

answer:

- 1) Confirm whether the radar transmitting probe is aligned with the measurement target;
- 2) Whether the measurement distance is within the reasonable range of the probe test.

### **Q: Why does the measured value jump frequently?**

answer:

- 1) Check if the power supply voltage is too low;
- 2) Whether there are obstacles in the measurement range;
- 3) Whether the probe installation is fixed firmly and whether the radar flow meter is installed parallel to the horizontal plane;
- 4) Check for vortices.

### **Q: Why is the measurement value not updated?**

answer:

- 1) Check if the water surface is frozen due to the season;
- 2) Check whether the radar wave covers the ground due to low water period or the main tank swinging, which may cause measurement errors.

### **Q: It is used to measure the surface flow during floods. The water flow is very fast, the water is rough, the water surface is rough, and there are many debris and floating objects. Can an accurate measurement result be obtained using a radar flow meter in this case?**

Answer: Yes. The turbulent water flow, coupled with floating objects on the water surface, can provide a good return signal for the radar speed probe. Please note that in this case, the radar speed probe will read multiple speeds with different sizes in different directions. A radar speed probe measures these speeds and averages them.

### **Q: The water surface has good roughness and the water surface is corrugated, but the radar speed probe's reading is still high and / or far below my expectations?**

Answer: Make sure not to get too far from the water when measuring. The specific distance is sometimes difficult to determine because the measurement is a function of the amount of signal returned to the radar speed probe. The returned signal is directly related to the distance of the radar speed probe from the water surface and the roughness of the water surface. The closer the radar speed probe is to the water surface, the better the measurement effect is, even in the case of low water velocity. Regularly observe whether the cross arm or other fixing mechanism where the flow meter is installed is inclined or loose due to external forces (such as high wind).

Question: I'm measuring water velocity below 0.60m/s visually, but the reading is higher than expected.

Answer: Check the effect of wind on the water surface. Wind may affect the measurement of low-speed water currents (such as those below 0.50m / s). If possible, measure in two directions, one is the direction of the water flow towards the radar speed probe and the other is the direction of the water flow away from the radar speed probe. Try pointing the radar speed probe at the same location for measurement.